

WHOLE TREE CHIPPER



Specification

Operating weight	35,000 lbs.
Chipping capacity	80 tons per hour
Gross engine power	440-630 hp
Engine options	Caterpillar- Cummins - John Deere

Features

- ▶ 30" wide by 50" diameter full pocket cutting drum
- ▶ 30" wide by 40" diameter feed roll
- ▶ Eaton FX control system
- ▶ Pressure compensated loads sensing hydraulic system
- ▶ Wireless remote control
- ▶ Skidded grab
- ▶ Dual stabilizer legs

WORKS FOR YOU.™

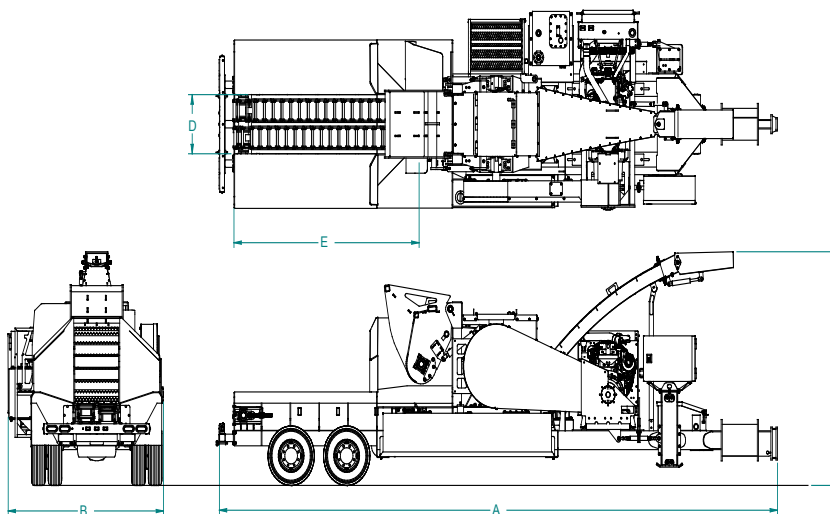

DIMENSIONS

A	Length	31'10" (969 cm)
B	Travel width	8'10" (269 cm)
C	Height	10'5" (316 cm)
D	Feed opening width	45" (115 cm)
E	Feed table length	10'7" (322 cm)
	Weight	Approximate, depending engine option 35,000 lbs. (16102 kg)
	Fuel tank	170 gallons
	Hydraulic tank	80 gallons

STANDARD EQUIPMENT

- Chipper drum: 50" diameter by 30" wide full pocket knife drum
- Feed wheel: 40" diameter by 30" wide, with 17 rows of flame harden serrated cutting teeth
- 4 way discharge chute give the operator the ability to spot two trailers for filling
- One touch adjustable feed speed from 60 to 120 feet per minute
- On screen diagnostics trouble shooting and maintenance
- Eaton FX Control system, with wireless remote control
- Bolt in replaceable wear parts: anvil bed ,belly band and discharge chute

OPTIONAL EQUIPMENT

- 3 and 4 pocket drums for smaller chip sizes
- Sizing screen and blower with 300 degree swivel discharge
- Track undercarriage
- Cab and loader
- PT tech electronic clutch
- Esbar cold weather heaters

www.terexwoodsman@terex.com

Product specifications and prices are subject to change without notice or obligation. The photographs and/or drawings in this document are for illustrative purposes only. Refer to the appropriate Operator's Manual for instructions on the proper use of this equipment. Failure to follow the appropriate Operator's Manual when using our equipment or to otherwise act irresponsibly may result in serious injury or death. The only warranty applicable to our equipment is the standard written warranty applicable to the particular product and sale and Terex makes no other warranty, express or implied. Products and services listed may be trademarks, service marks or trade-names of Terex Corporation and/or its subsidiaries in the USA and other countries. All rights are reserved. Terex is a registered trademark of Terex Corporation in the USA and many other countries.
© 2011 Terex Corporation.

Terex Woodsman
1250 Commerce Drive
Farwell, MI 48622 USA
Tel +1 (989) 588-4295
terexwoodsman.sales@terex.com



WORKS FOR YOU.™