

# WHOLE TREE CHIPPER



## Specification

Operating weight	58,000 lbs.
Chipping capacity	160 tons per hour
Gross engine power	540-765 hp
Engine options	Caterpillar - Cummins

## Features

- ▶ 45" wide by 50" diameter full pocket cutting drum
- ▶ 45" wide by 40" diameter feed roll
- ▶ Eaton FX control system
- ▶ Pressure compensated loads sensing hydraulic system
- ▶ Wireless remote control
- ▶ Superior feed system design uses no "chain and sprocket" drives
- ▶ Dual stabilizer legs

**WORKS FOR YOU.™**

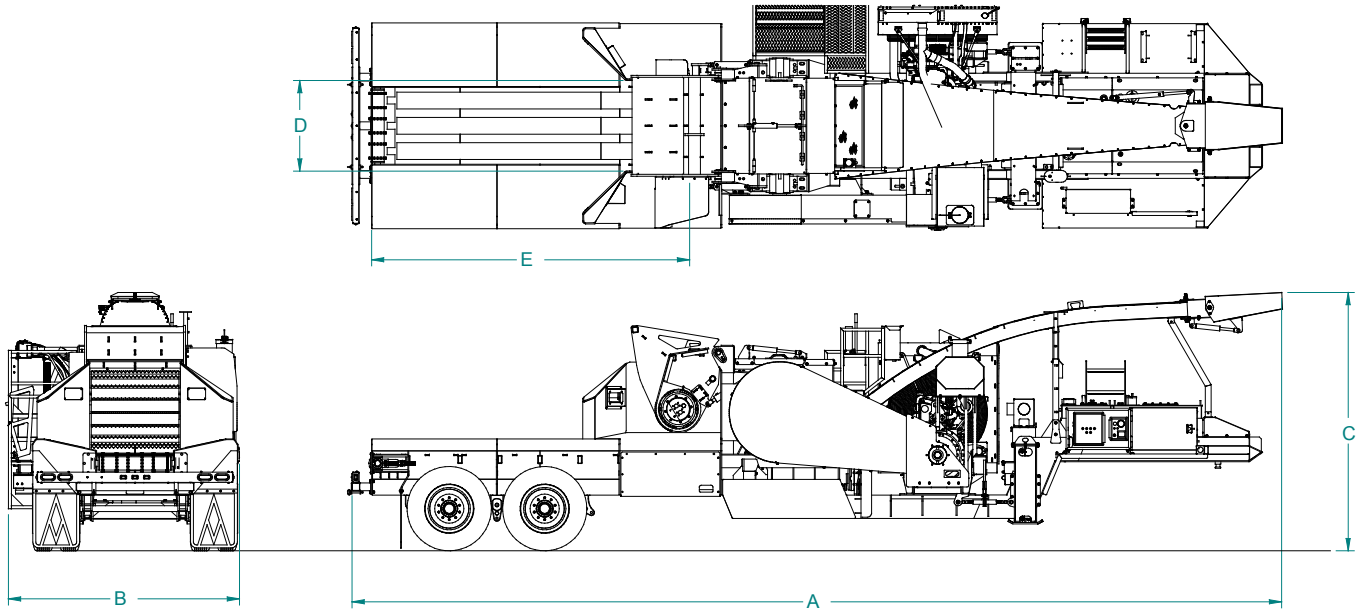

## DIMENSIONS

A	Length	39'10" (1211 cm)
B	Travel width	9'11" (301 cm)
C	Height	11'1" (336 cm)
D	Feed opening width	45" (115 cm)
E	Feed table length	13'7" (414 cm)
	Weight	Approximate, depending engine option 58,000 lbs. (26308 kg)
	Fuel tank	210 gals (795 L)
	Hydraulic tank	105 gals (397 L)

## STANDARD EQUIPMENT

Chipper drum: 50" diameter by 45" wide full pocket knife drum

Feed wheel: 40" diameter by 45" wide, with 17 rows of flame harden serrated cutting teeth

4 way discharge chute give the operator the ability to spot two trailers for filling

One touch adjustable feed speed from 60 to 120 feet per minute

On screen diagnostics trouble shooting and maintenance

Eaton FX Control system, with wireless remote control

Bolt in repalceable wear parts: anvil bed ,belly band and discharge chute

## OPTIONAL EQUIPMENT

3 and 4 pocket drums for smaller chip sizes

Sizing screen and blower with 300 degree swivel discharge

Track undercarriage

Cab and loader

PT tech electronic clutch

Esbar cold weather heaters

[www.terexwoodsman@terex.com](mailto:www.terexwoodsman@terex.com)

Product specifications and prices are subject to change without notice or obligation. The photographs and/or drawings in this document are for illustrative purposes only. Refer to the appropriate Operator's Manual for instructions on the proper use of this equipment. Failure to follow the appropriate Operator's Manual when using our equipment or to otherwise act irresponsibly may result in serious injury or death. The only warranty applicable to our equipment is the standard written warranty applicable to the particular product and sale and Terex makes no other warranty, express or implied. Products and services listed may be trademarks, service marks or trade-names of Terex Corporation and/or its subsidiaries in the USA and other countries. All rights are reserved. Terex is a registered trademark of Terex Corporation in the USA and many other countries.

© 2011 Terex Corporation.

Terex Woodsman  
1250 Commerce Drive  
Farwell, MI 48622 USA  
Tel +1 (989) 588-4295  
terexwoodsman.sales@terex.com



**WORKS FOR YOU.™**